

# 中銀香港第五十二屆體育節 龍舟比賽

## 比賽賽制 (一)

比賽組別: 大專組 (7 隊)

賽程: 小龍 200 米

### 1. 比賽場次及成績計算:

- ◇ 分初賽，複賽及決賽。
- ◇ 初賽分二組。每組之第一名將直接進入該組別之決賽。餘下各隊將進入複賽。
- ◇ 複賽之前四名將進入該組別之決賽。餘下各隊將被淘汰出局。

### 2. 賽道及對賽隊伍之安排:

- ◇ 初賽之線道及對賽隊伍之安排，將在 2009 年 4 月 15 日(星期三)領隊會議中以抽籤方式分配。
- ◇ 複賽之線道及對賽隊伍之安排，將依各隊之初賽比賽時間計算如下:

複賽賽道分配	1	2	3	4	5	6
餘下初賽隊伍依時間之名次	5	3	1	2	4	6

- ◇ 決賽之線道安排將根據初賽及複賽之名次分配賽道如下:

決賽賽道分配	1	2	3	4	5	6
初賽及複賽之名次	複賽第三名	複賽第一名	初賽第一名(最快時間)	初賽第一名	複賽第二名	複賽第四名

# 中銀香港第五十二屆體育節 龍舟比賽

## 比賽賽制 (一) 大專組 (7 隊)

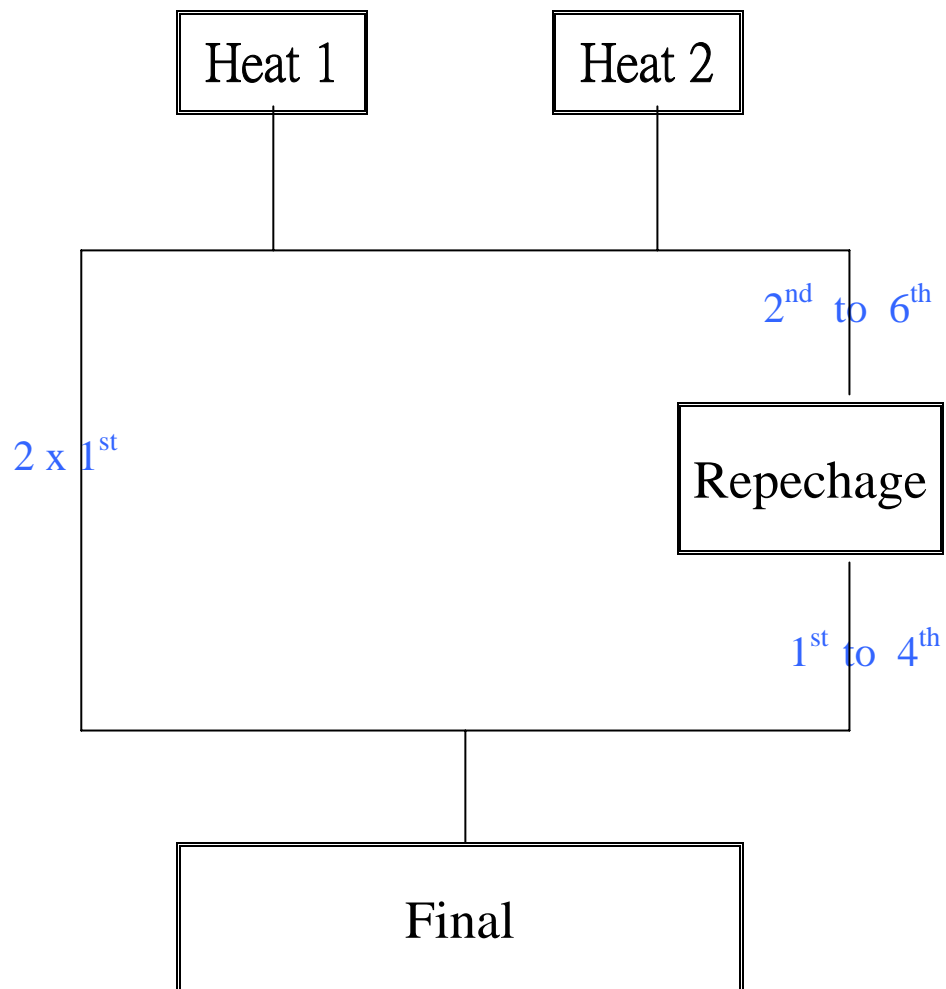

# Bank of China (Hong Kong) 52nd Festival of Sports - Dragon Boat

## Competition Race Format (1)

**Race Categories:** Post-Secondary Colleges' Championships (7 crews)

**Race Course:** 200 Meters (Small Dragon Boat)

### (1) Race and Scoring

- ✧ Each Category has Heat, Repechage & Final races.
- ✧ The Heat will divide into 2 groups in each category. The 1<sup>st</sup> ranking of each group will enter the Final race directly. The other remain teams will combine to Repechage race.
- ✧ The 1<sup>st</sup> to 4<sup>th</sup> ranking in Repechage will also enter the Final race.

### (2) Race Lane Allocation:

- ✧ The Heat races lane which will be arranged by the drawing from the team manager meeting held on 15<sup>th</sup> April 2009.
- ✧ The Repechage race lane will be allocated according to the finishing time in Heat races of the remain six teams as following:

<b>The Repechage race Lane</b>	<b>1</b>	<b>2</b>	<b>3</b>	<b>4</b>	<b>5</b>	<b>6</b>
The ranking of finishing time in Heat except the 1 <sup>st</sup> ranking in each group.	5 <sup>th</sup> best time	3 <sup>rd</sup> best time	1 <sup>st</sup> best time	2 <sup>nd</sup> best time	4 <sup>th</sup> best time	6 <sup>th</sup> best time

- ✧ The Final race lane will be allocated according to the finishing time & ranking in Heat & Repechage races as following:

<b>The Final race Lane</b>	<b>1</b>	<b>2</b>	<b>3</b>	<b>4</b>	<b>5</b>	<b>6</b>
The finishing time & ranking in Heat & Repechage races	3 <sup>rd</sup> in Repec hage	1 <sup>st</sup> in Repec hage	1 <sup>st</sup> in Heat (best time)	1 <sup>st</sup> in Heat	2 <sup>nd</sup> in Repec hage	4 <sup>th</sup> in Repec hage

# 中銀香港第五十二屆體育節 龍舟比賽

## 比賽賽制(二)

比賽組別: 女子組 (11 隊)

賽程: 小龍 200 米

### 1. 比賽場次及成績計算:

- ◇ 分初賽, 複賽及決賽。
- ◇ 初賽分二組。每組之第一名將直接進入該組別之決賽。餘下各隊將進入複賽。
- ◇ 複賽分二組。每組之前二名將進入該組別之決賽。餘下各隊將被淘汰出局。

### 2. 賽道及對賽隊伍之安排:

- ◇ 初賽之線道及對賽隊伍之安排, 將在 2009 年 4 月 15 日(星期三)領隊會議中以抽籤方式分配。
- ◇ 複賽之線道及對賽隊伍之安排, 將依各隊之初賽比賽時間計算如下:

A 組複賽賽道分配	1	2	3	4	5	6
◇ 餘下初賽隊伍依時間之名次	9	5	1	3	7	11
B 組複賽賽道分配	1	2	3	4	5	6
◇ 餘下初賽隊伍依時間之名次	10	6	2	4	8	12

- ◇ 決賽之線道安排將根據初賽及複賽之名次分配賽道如下:

決賽賽道分配	1	2	3	4	5	6
初賽及複賽之名次	▷ 組複賽第二名	▷ 組複賽第一名	▷ 組初賽第一名	▷ 組初賽第一名	▷ 組複賽第一名	▷ 組複賽第二名

中銀香港第五十二屆體育節 龍舟比賽

比賽賽制(二) 女子組 (11 隊)

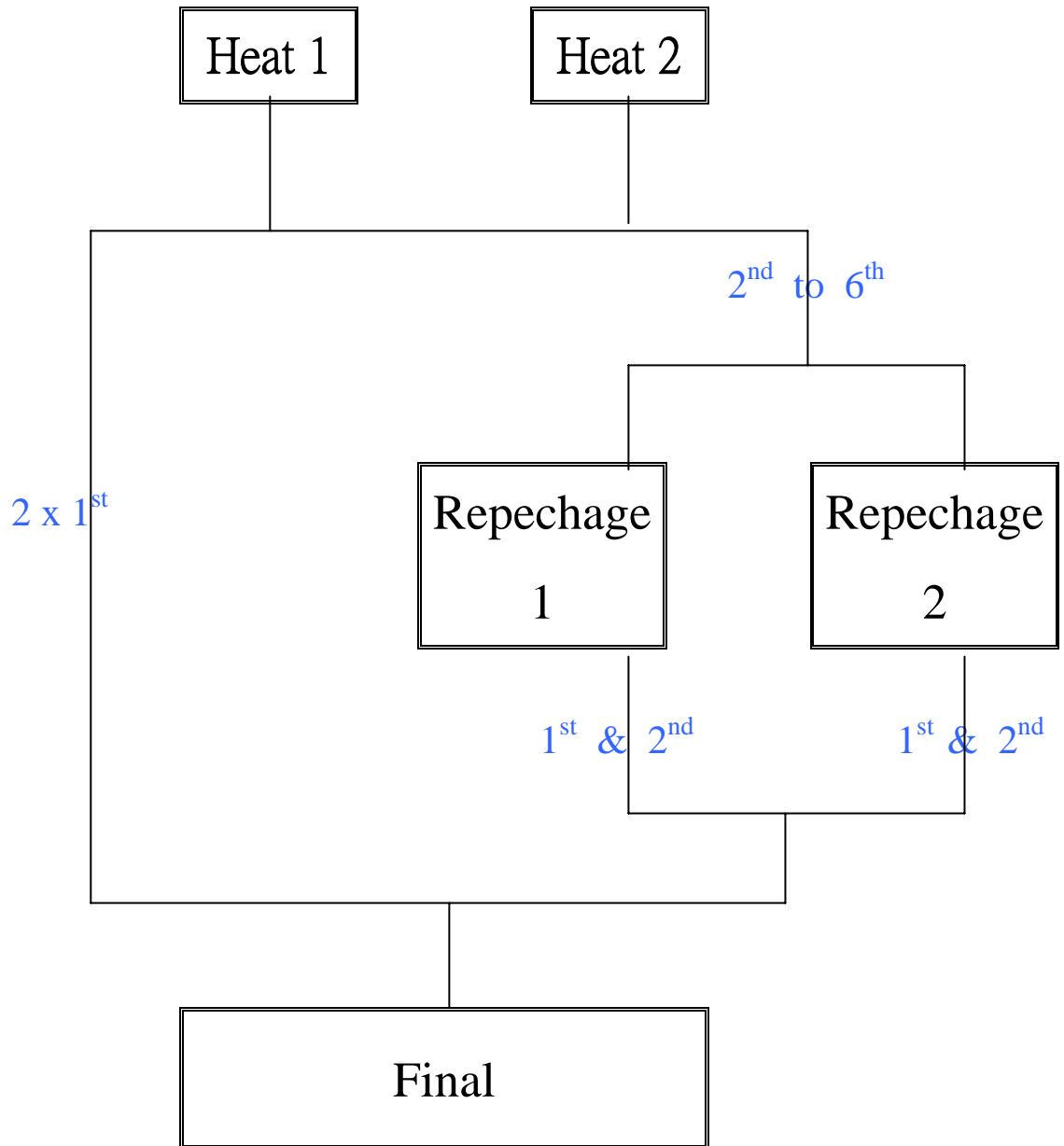

## Bank of China (Hong Kong) 52nd Festival of Sports - Dragon Boat Competition

### Race Format (2)

**Race Categories: Women's Championships (9/11 crews)**

**Race Course: 200 Meters (Small Dragon Boat)**

1. Race and Scoring

- ✧ Each Category has Heat, Repechage & Final races.
- ✧ The Heat will divide into 2 groups. The 1<sup>st</sup> ranking of each group will enter the Final race directly. The other remain teams will enter to Repechage race.
- ✧ The 1<sup>st</sup> & 2<sup>nd</sup> of group ranking in Repechages will also enter the Final race.

2. Race Lane Allocation:

- ✧ The 1<sup>st</sup> round race lane which will be arranged by the drawing from the team manager meeting held on 15<sup>th</sup> April 2009.
- ✧ The Semi-final race lane will be allocated according to the finishing time in Heat races of the remain teams as following:

<b>The Repechage Lane for Group A</b>	<b>1</b>	<b>2</b>	<b>3</b>	<b>4</b>	<b>5</b>	<b>6</b>
The ranking of finishing time in Heat except the 1 <sup>st</sup> ranking in each group.	9 <sup>th</sup> best time	5 <sup>th</sup> best time	1 <sup>st</sup> best time	3 <sup>rd</sup> best time	7 <sup>th</sup> best time	11 <sup>th</sup> best time
<b>The Repechage Lane for Group B</b>	<b>1</b>	<b>2</b>	<b>3</b>	<b>4</b>	<b>5</b>	<b>6</b>
The ranking of finishing time in Heat except the 1 <sup>st</sup> ranking in each group.	10 <sup>th</sup> best time	6 <sup>th</sup> best time	2 <sup>nd</sup> best time	4 <sup>th</sup> best time	8 <sup>th</sup> best time	12 <sup>th</sup> best time

- ✧ The Final race lane will be allocated according to the finishing time & ranking in Heat & Repechage races as following:

<b>The Final race Lane</b>	<b>1</b>	<b>2</b>	<b>3</b>	<b>4</b>	<b>5</b>	<b>6</b>
The ranking in Heat & Repechage races.	2 <sup>nd</sup> in Repech age (Group A)	1 <sup>st</sup> in Repech age (Group B)	1 <sup>st</sup> in Heat (Group A)	1 <sup>st</sup> in Heat (Group B)	1 <sup>st</sup> in Repech age (Group A)	2 <sup>nd</sup> in Repech age (Group B)

# 中銀香港第五十二屆體育節 龍舟比賽

## 比賽賽制(三)

比賽組別: 商行組 (5 隊), 青少年組 (6 隊), 壯年組 (6 隊)

賽程: 小龍 200 米

### 1. 比賽場次及成績計算:

- ◇ 每組每隊會比賽二個回合。每回合將根據其衝線名次給予分數，如沒完成或缺席者為零分。
- ◇ 每組每隊二個回合之分數總和為該組別之名次。

衝線名次	1	2	3	4	5	6
所得分數	7	5	4	3	2	1

- ◇ 和分: 若有賽隊二個回合所得之總分相同，則計算兩個回合之衝線所需時間的總和，最少時間者為勝。若時間總和仍相同，則以第二回合之成績定名次。(先計算名次，若相同則計算時間)

### 2. 賽道及對賽隊伍之安排:

- ◇ 每組首回合之線道及對賽隊伍之安排，將在 2009 年 4 月 15 日(星期三)領隊會議中以抽籤方式分配。
- ◇ 次回合之線道安排將根據首回合之線道另加三條線道如下:

次回合賽道分配	1	2	3	4	5	6
首回合賽道分配	首回合第 1 線道	首回合第 2 線道	首回合第 3 線道	首回合第 4 線道	首回合第 5 線道	首回合第 6 線道

## Bank of China (Hong Kong) 52nd Festival of Sports - Dragon Boat Competition

### Race Format (3)

**Race Categories:**           **Inter-Company Championships (5 crews)**  
                                  **Junior Championships (6 crews)**  
                                  **Senior Championships (6 crews)**

**Race Course:**   **200 Meters (Small Dragon Boat)**

#### 1. Race and Scoring

- ✧ Each Category has 2 round races. Each team will score points according to the finishing position from each round race while absentees (DNS- Do not start ) or those who do not finish (DNF) the race or disqualified will gain zero.
- ✧ The result will be the total score of the 2 round races.
- ✧ The highest total score will be the champion. The second and third higher score will be the 1<sup>st</sup> runner up and 2<sup>nd</sup> runner up respectively.

<b>Finishing Position</b>	<b>1</b>	<b>2</b>	<b>3</b>	<b>4</b>	<b>5</b>	<b>6</b>
Score	7	5	4	3	2	1

- ✧ Tie: If teams get the same total scores, they shall be ranked in order of their total finishing time scores in the two round races, the less time will win. If tie still happen they shall be ranked in order of the 2<sup>nd</sup> round races.

#### 2. Race Lane Allocation:

- ✧ The 1<sup>st</sup> round race lane which will be arranged by the drawing from the team manager meeting held on 15<sup>th</sup> April 2009.
- ✧ The 2<sup>nd</sup> round race lane which will be shifted to next 3 lanes according to the 1<sup>st</sup> round race lane allocation as following:

<b>The 2<sup>nd</sup> round race Lane</b>	<b>1</b>	<b>2</b>	<b>3</b>	<b>4</b>	<b>5</b>	<b>6</b>
The 1 <sup>st</sup> round lane allocation	1st round lane 4	1st round lane 5	1st round lane 6	1st round lane 1	1st round lane 2	1st round lane 3

# 中銀香港第五十二屆體育節 龍舟比賽

## 比賽賽制(四)

比賽組別: 公開組 (24 隊)

賽程: 小龍 200 米

### 1. 比賽場次及成績計算:

- ◇ 分初賽，複賽，**準決賽**及決賽。
- ◇ 初賽分四組。每組之第一至第三名將直接進入該組別之準決賽。餘下各隊將進入 2009/4/14 複賽。
- ◇ 初賽複賽分二組。每組之前三名將進入該組別之準決賽。餘下各隊將被淘汰出局。
- ◇ 準決賽分三組。每組之前二名將進入該組別之決賽。餘下各隊將被淘汰出局。

### 2. 賽道及對賽隊伍之安排:

- ◇ 初賽之線道及對賽隊伍之安排，將在 2009 年 4 月 15 日 (星期三)領隊會議中以抽籤方式分配。
- ◇ 複賽之線道及對賽隊伍之安排，將依各隊之初賽比賽時間計算如下:

<b>A 組複賽賽道分配</b>	<b>1</b>	<b>2</b>	<b>3</b>	<b>4</b>	<b>5</b>	<b>6</b>
◇餘下初賽隊伍依時間之名次	9	5	1	3	7	11
<b>B 組複賽賽道分配</b>	<b>1</b>	<b>2</b>	<b>3</b>	<b>4</b>	<b>5</b>	<b>6</b>
◇餘下初賽隊伍依時間之名次	10	6	2	4	8	12

- ◇ 準決賽之線道安排將根據初賽及複賽之名次分配賽道如下:

A 組準決賽賽道分配	1	2	3	4	5	6
初賽及複賽依時間之名次	複賽第三名	初賽第七名	初賽第一名	初賽第六名	初賽第十二名	複賽第六名

B 組準決賽賽道分配	1	2	3	4	5	6
初賽及複賽依時間之名次	複賽第二名	初賽第八名	初賽第二名	初賽第五名	初賽第十一名	複賽第五名

C 組準決賽賽道分配	1	2	3	4	5	6
初賽及複賽依時間之名次	複賽第一名	初賽第九名	初賽第三名	初賽第四名	初賽第十名	複賽第四名

✧ 決賽之線道安排將根據初賽及複賽之名次分配賽道如下:

決賽賽道分配	1	2	3	4	5	6
準決賽之名次	Ⓚ組準決賽第二名	Ⓛ組準決賽第一名	Ⓜ組準決賽第一名	Ⓨ組準決賽第一名	Ⓩ組準決賽第二名	Ⓟ組準決賽第二名

中銀香港第五十二屆體育節 龍舟比賽

比賽賽制(四) 公開組 (24 隊)

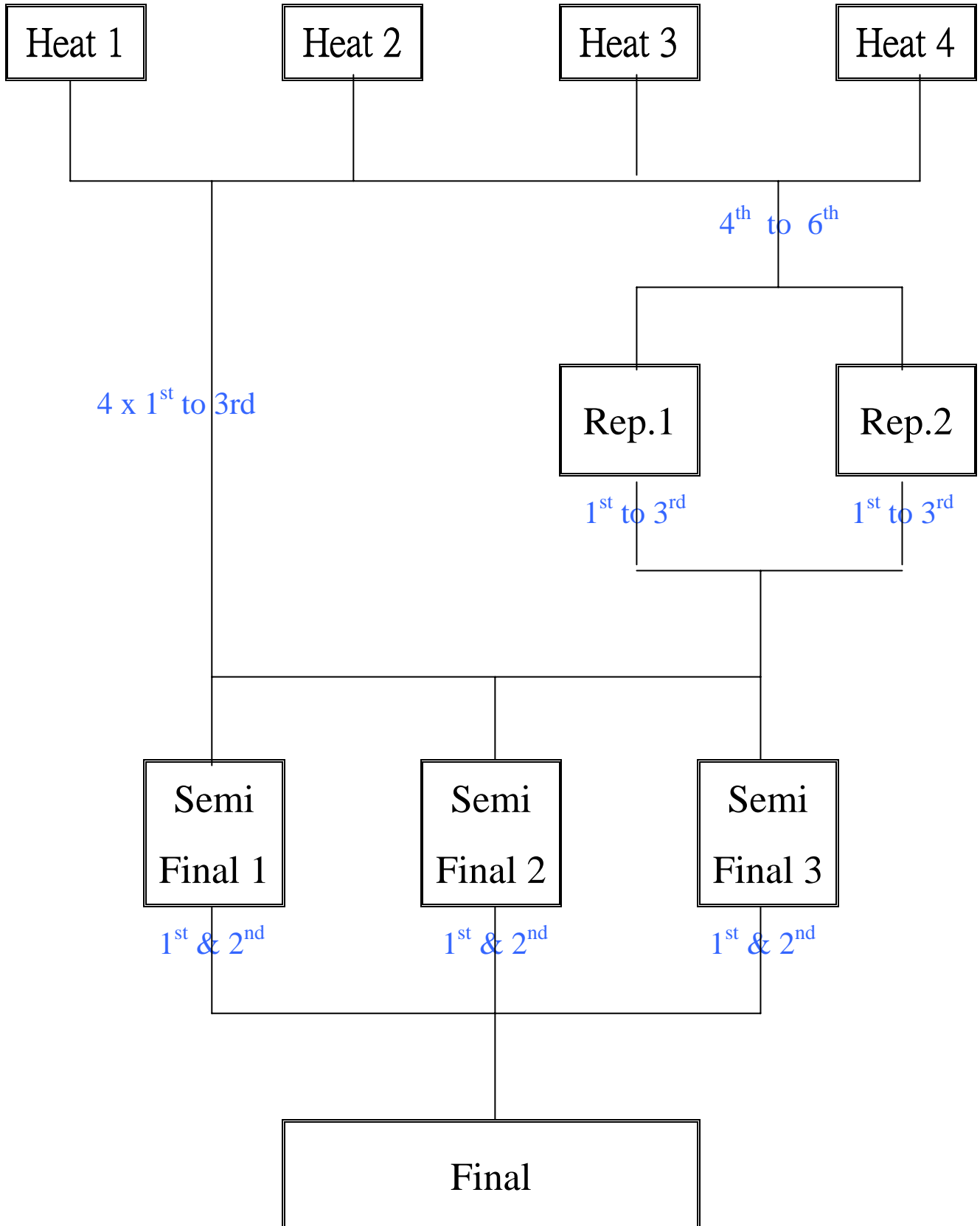

## Bank of China (Hong Kong) 52nd Festival of Sports - Dragon Boat Competition

### Race Format (4)

**Race Categories: Open Championships (24 crews)**

**Race Course: 200 Meters (Small Dragon Boat)**

#### 3. Race and Scoring

- ✧ Each Category has Heat, Repechage, Semi-final & Final races.
- ✧ The Heat will divide into 4 groups. The first three crews in each Heat will go to the Semi-Final race directly. The other remain teams will go to the Repechage races.
- ✧ The Repechage will divide into 2 groups. The first three crews will go to the Semi-Final races.
- ✧ The Semi-final will divide into 3 groups. The 1<sup>st</sup> & 2<sup>nd</sup> of group ranking in Semi-final races will go to the Final race.

#### 4. Race Lane Allocation:

- ✧ The 1<sup>st</sup> round race lane which will be arranged by the drawing from the team manager meeting held on 15<sup>th</sup> April 2009.
- ✧ The Repechage races lane will be allocated according to the finishing time in Heat races of the remain teams (4<sup>th</sup> to 6<sup>th</sup>) as following:

<b>The Repechage race Lane for Group A</b>	<b>1</b>	<b>2</b>	<b>3</b>	<b>4</b>	<b>5</b>	<b>6</b>
The ranking of finishing time in overall remaining crews (4 <sup>th</sup> to 6 <sup>th</sup> ) in Heats.	9 <sup>th</sup> best time	5 <sup>th</sup> best time	1 <sup>st</sup> best time	3 <sup>rd</sup> best time	7 <sup>th</sup> best time	11 <sup>th</sup> best time
<b>The Repechage race Lane for Group B</b>	<b>1</b>	<b>2</b>	<b>3</b>	<b>4</b>	<b>5</b>	<b>6</b>
The ranking of finishing time in overall remaining crews (4 <sup>th</sup> to 6 <sup>th</sup> ) in Heats.	10 <sup>th</sup> best time	6 <sup>th</sup> best time	2 <sup>nd</sup> best time	4 <sup>th</sup> best time	8 <sup>th</sup> best time	12 <sup>th</sup> best time

✧ The Semi-Final races lane will be allocated according to the finishing time & ranking in Heat & Repechage races as following:

<b>The Repechage race Lane for Group A</b>	<b>1</b>	<b>2</b>	<b>3</b>	<b>4</b>	<b>5</b>	<b>6</b>
The ranking of finishing time in overall Heats & the ranking in Repechages.	3 <sup>rd</sup> best time in Rep.	7 <sup>th</sup> best time in Heats	1 <sup>st</sup> best time in Heats	6 <sup>th</sup> best time in Heats	12 <sup>th</sup> best time in Heats	6 <sup>th</sup> best time in Rep.
<b>The Repechage race Lane for Group B</b>	<b>1</b>	<b>2</b>	<b>3</b>	<b>4</b>	<b>5</b>	<b>6</b>
The ranking of finishing time in overall Heats & the ranking in Repechages.	2 <sup>nd</sup> best time in Rep.	8 <sup>th</sup> best time in Heats	2 <sup>nd</sup> best time in Heats	5 <sup>th</sup> best time in Heats	11 <sup>th</sup> best time in Heats	5 <sup>th</sup> best time in Rep.
<b>The Repechage race Lane for Group C</b>	<b>1</b>	<b>2</b>	<b>3</b>	<b>4</b>	<b>5</b>	<b>6</b>
The ranking of finishing time in overall Heats & the ranking in Repechages.	1 <sup>st</sup> best time in Rep.	9 <sup>th</sup> best time in Heats	3 <sup>rd</sup> best time in Heats	4 <sup>th</sup> best time in Heats	10 <sup>th</sup> best time in Heats	4 <sup>th</sup> best time in Rep.

✧ The Final race lane will be allocated according to the ranking in Semi-final races as following:

<b>The Final race Lane</b>	<b>1</b>	<b>2</b>	<b>3</b>	<b>4</b>	<b>5</b>	<b>6</b>
The ranking in Semi-final races.	2 <sup>nd</sup> in Semi final (Group B)	1 <sup>st</sup> in Semi final (Group C)	1 <sup>st</sup> in Semi final (Group A)	1 <sup>st</sup> in Semi final (Group B)	2 <sup>nd</sup> in Semi final (Group A)	2 <sup>nd</sup> in Semi final (Group C)

# 中銀香港第五十二屆體育節 龍舟比賽

## 比賽賽制(五)

比賽組別: 混合組 (14 隊)

賽程: 小龍 200 米

### 1. 比賽場次及成績計算:

- ◇ 分初賽，複賽，**準決賽**及決賽。
- ◇ 初賽分三組。每組之第一至第三名將直接進入該組別之準決賽。餘下各隊將合併進行複賽。
- ◇ 複賽之前三名將進入該組別之準決賽。餘下各隊將被淘汰出局。
- ◇ 準決賽分二組。每組之前三名將進入該組別之決賽。餘下各隊將被淘汰出局。

### 2. 賽道及對賽隊伍之安排：

- ◇ 初賽之線道及對賽隊伍之安排，將在 2009 年 4 月 15 日 (星期三)領隊會議中以抽籤方式分配。
- ◇ 複賽之線道及對賽隊伍之安排，將依各隊之初賽比賽時間計算如下:

複賽賽道分配	1	2	3	4	5	6
◇餘下初賽隊伍依時間之名次	5	3	1	2	4	6

◇ 準決賽之線道安排將根據初賽及複賽之名次分配賽道如下:

A 組準決賽賽道分配	1	2	3	4	5	6
初賽及複賽依時間之名次	複賽第一名	初賽第五名	初賽第一名	初賽第三名	初賽第八名	複賽第三名

B 組準決賽賽道分配	1	2	3	4	5	6
初賽及複賽依時間之名次	初賽第九名	初賽第六名	初賽第二名	初賽第四名	初賽第七名	複賽第二名

◇ 決賽之線道安排將根據初賽及複賽之名次分配賽道如下:

決賽賽道分配	1	2	3	4	5	6
初賽及複賽之名次	▷ 組準決賽第三名	⊖ 組準決賽第二名	▷ 組準決賽第一名	⊖ 組準決賽第一名	▷ 組準決賽第二名	⊖ 組準決賽第三名

# 中銀香港第五十二屆體育節 龍舟比賽

## 比賽賽制(五) 混合組 (14 隊)

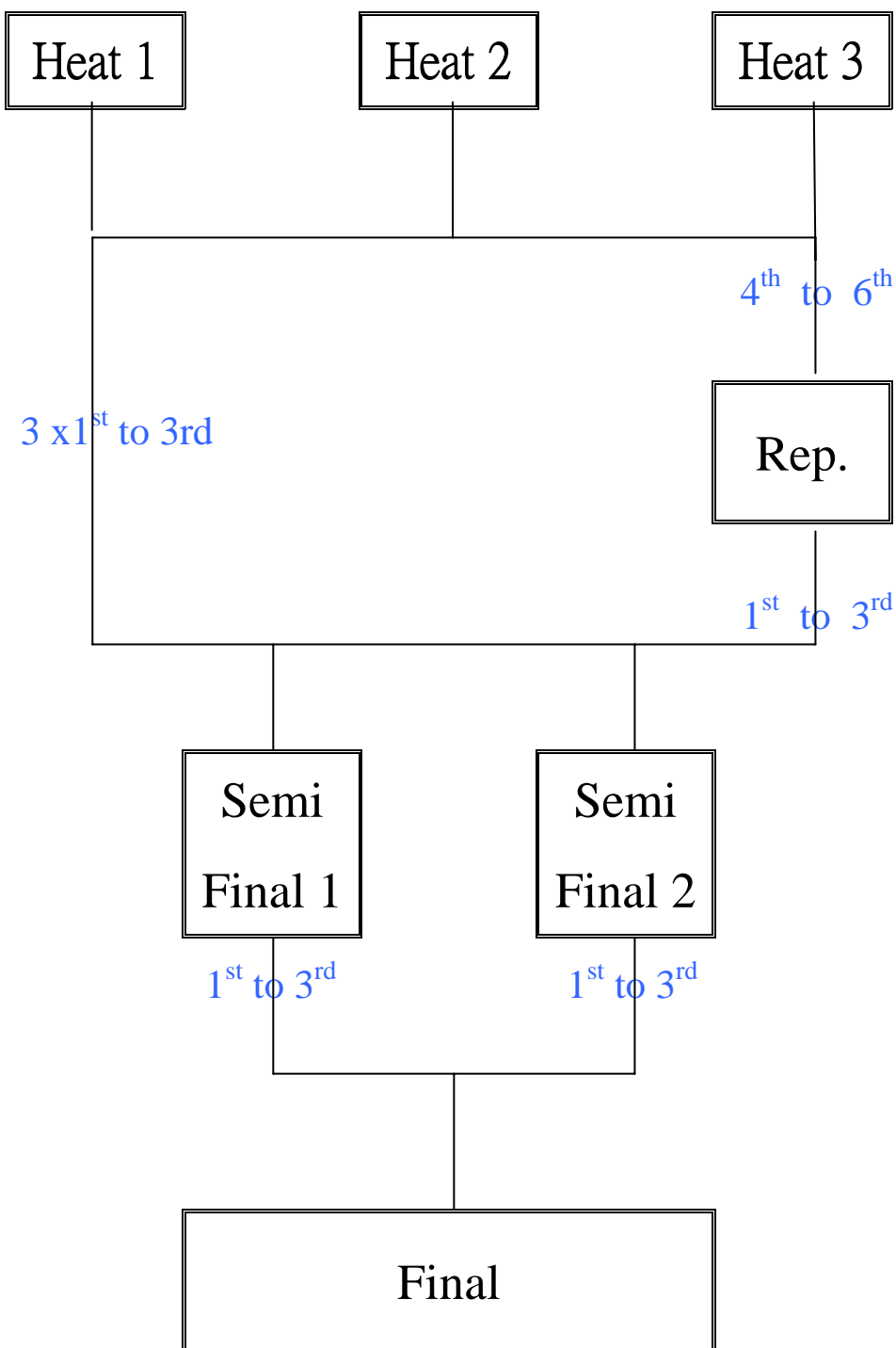

## Bank of China (Hong Kong) 52nd Festival of Sports - Dragon Boat Competition

### Race Format (5)

**Race Categories: Mixed Championships (14 crews)**

**Race Course: 200 Meters (Small Dragon Boat)**

#### 5. Race and Scoring

- ✧ Each Category has Heat, Repechage, Semi-final & Final races.
- ✧ The Heat will divide into 3 groups. The first three crews in each Heat will go to the Semi-Final race directly. The other remain teams will combine to the Repechage race.
- ✧ The first three crews in Repechage will go to the Semi-Final races.
- ✧ The Semi-final will divide into 2 groups. The 1<sup>st</sup> to 3<sup>rd</sup> of group ranking in semi-final races will go to the Final race.

#### 3. Race Lane Allocation:

- ✧ The 1<sup>st</sup> round race lane which will be arranged by the drawing from the team manager meeting held on 15<sup>th</sup> April 2009..
- ✧ The Repechage race lane will be allocated according to the finishing time in Heat races of the remain teams as following:

<b>The Repechage race Lane</b>	<b>1</b>	<b>2</b>	<b>3</b>	<b>4</b>	<b>5</b>	<b>6</b>
The ranking of finishing time in overall remaining crews in Heats.	5 <sup>th</sup> best time	3 <sup>rd</sup> best time	1 <sup>st</sup> best time	2 <sup>nd</sup> best time	4 <sup>th</sup> best time	6 <sup>th</sup> best time

✧ The Semi-final races lane will be allocated according to the finishing time in Heat races & Repechage as following:

<b>The Semi-final race Lane for Group A</b>	<b>1</b>	<b>2</b>	<b>3</b>	<b>4</b>	<b>5</b>	<b>6</b>
The ranking of finishing time in overall Heats & the ranking in Repechage	1 <sup>st</sup> in Rep.	5 <sup>th</sup> best time in Heats	1 <sup>st</sup> best time in Heats	3 <sup>rd</sup> best time in Heats	8 <sup>th</sup> best time in Heats	3 <sup>rd</sup> in Rep.
<b>The Semi-final race Lane for Group B</b>	<b>1</b>	<b>2</b>	<b>3</b>	<b>4</b>	<b>5</b>	<b>6</b>
The ranking of finishing time in overall Heats & the ranking in Repechage	9 <sup>th</sup> best time in Heats	6 <sup>th</sup> best time in Heats	2 <sup>nd</sup> best time in Heats	4 <sup>th</sup> best time in Heats	7 <sup>th</sup> best time in Heats	2 <sup>nd</sup> in Rep.

✧ The Final race lane will be allocated according to the finishing time & ranking in Heat & Semi-final races as following:

<b>The Final race Lane</b>	<b>1</b>	<b>2</b>	<b>3</b>	<b>4</b>	<b>5</b>	<b>6</b>
The ranking in Semi-final races.	3 <sup>rd</sup> in Semi final (Group A)	2 <sup>nd</sup> in Semi final (Group B)	1 <sup>st</sup> in Semi final (Group A)	1 <sup>st</sup> in Semi final (Group B)	2 <sup>nd</sup> in Semi final (Group A)	3 <sup>rd</sup> in Semi final (Group B)